

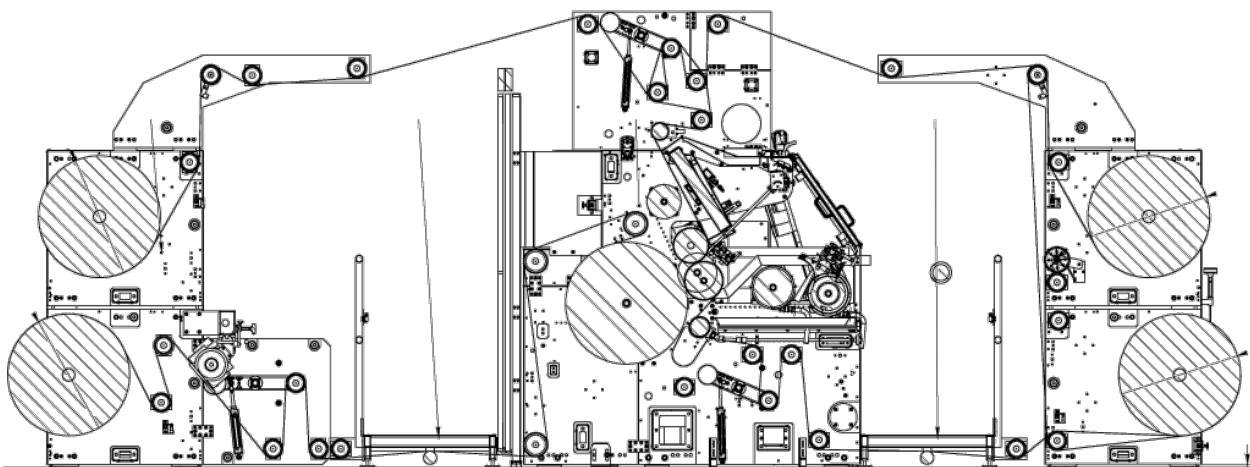

For our customers' products:

- Multifunctional duplex and triplex laminates for sports and leisure clothing (e.g. outdoor)
- Protective workwear
- Heat protection articles (e.g. clothing, non-garment)
- Laminated and coated materials for the automotive industry (interior fittings)
- Foam or fleece laminated upholstery fabrics
- Laminates and coatings for the shoe industry
- Textile coatings for non-slip finishing or other functional layers
- Coated and laminated nonwoven
- Disposable or reusable items in the medical sector
- Coated and laminated composites for industrial applications
- Carpet backing coatings for pile consolidation or secondary backing lamination



Multi-winder
with edge-cutting unit

Multipurpose laminating-
and coating unit

Multi-unwinder

